

DESIGN AND FABRICATION OF A HIGH-EFFICIENCY ELECTRIC SCOOTER FOR URBAN MOBILITY

Muiz Asghar¹, Amna Hafeez², *Shoukat Ali Noonari³, Sagheer Ahmed⁴, Aziz ur Rahman⁵, Faiza Anam⁶

¹ District Supervisor Energy Department Govt of Sindh

² ³ ⁴ Department of Mechanical Engineering Isra University Hyderabad, Sindh, Pakistan.

⁵ Addl S.E (operation) DG Khan MEPCO

⁶ Electrical Engineering Department Mehran UET Jamshoro

*Corresponding Author: (Shoukat.noonari88@yahoo.com)

Article Info



This article is an open access article distributed under the terms and conditions of the Creative Commons Attribution (CC BY) license <https://creativecommons.org/licenses/by/4.0>

Abstract

Electric vehicles, especially electric scooters, are increasingly being adopted in cities as people look for cleaner and more efficient transportation options. This paper focuses on the design and development of an electric scooter that provides a useful, economical and sustainable solution for daily urban travelling. The design process started with an analysis of user needs and market trends, followed by a review of the latest advancements in areas such as motor efficiency, battery performance and lightweight structural materials. Based on this study, a detailed design specification was prepared, addressing important factors like top speed, travel distance, cost and also safety. While during the development phase several prototype models were built and tested to analyze performance and reliability. With the helped of these tests the design of electrical scooters was improved and ensure compliance with safety and regulatory standards. The final design combines key parts such as a brushless DC motor, a regenerative braking system, and a high-capacity lithium-ion battery pack. Extra features, like energy monitoring and smart connectivity were also included to make it easier for users. Sustainability remained a major focus in the paper with efforts made to minimize energy-efficient components and environmental impact by using recyclable materials. overall the designed electric scooter introduces a durable alternative to usual petrol diesel based vehicles for nearby travel distance

Keywords: *Electric scooter, Sustainable transportation, Design and development, Urban commuting, Battery technology, Lightweight materials*

1. Introduction

Since the early twenty-first century, micro-mobility solutions particularly lightweight electric vehicles have transformed the way people travel within cities. The rise of scooter sharing programs, supported by advances in mobile applications, telecommunication systems, and charging infrastructure, has accelerated the adoption of electric scooters in both docked and dock less formats. [1]. The main aim of this paper is to design and development of electrical scooter A key innovation is the integration of a clutch mechanism and gearbox, which improve power transmission and energy efficiency. High-strength, lightweight materials were used to reduce structural mass, while aerodynamic refinements helped lower drag and enhance visual appeal. Replacing electronic speed controllers with a mechanical transmission not only improved power utilization but also reduced the likelihood of electronic failures. The designed prototype provides useful and efficient system for urban mobility and offers an opportunity for future advancements in micro mobility technology

2. Literature Review

Electric cars play a vital role in reducing dependence on fossil fuels and offer substantial environmental advantages. However, ensuring public accessibility requires significant investment and careful planning in the development of charging infrastructure. One of the major challenges faced by manufacturers in promoting electric mobility is the limited availability of charging stations. Conventional gasoline and diesel-powered vehicles emit harmful pollutants such as sulfur oxides, carbon monoxide, nitrogen oxides, and hydrocarbons, which severely degrade air quality and contribute to environmental damage. According to the World Health Organization, outdoor air pollution is responsible for approximately 3.7 million deaths each year, with diesel-powered vehicles contributing up to 50% of these deaths in European cities and over 30% in several other regions. India is the fourth-largest producer of passenger cars and ranks fifth globally in overall vehicle production [3]. The integration of electric scooters into Hungary's urban transportation network represents an innovative mobility approach that can enhance environmental quality and create new economic opportunities, thereby improving citizens' overall quality of life. This article examines government-level policy initiatives aimed at facilitating such integration. Furthermore, a Quality Function Deployment (QFD) approach is employed to incorporate user perspectives and identify policy gaps concerning e-scooters. The study draws upon a combination of methods, including literature review, qualitative analysis of social media content, interviews with government officials, seven focus group discussions, and a structured survey. These diverse data sources provide a comprehensive view of the current situation and highlight key opportunities for improvement. By developing a QFD framework, the study establishes clear priorities for tackling existing challenges and guiding potential enhancements. The findings reveal that users strongly support the introduction of new e-scooter regulations, particularly those aimed at optimizing speed limits, improving dedicated infrastructure, and providing designated parking spaces. Such insights are valuable for government policymakers as they design future e-scooter policies. Addressing user expectations and integrating these perspectives into regulatory frameworks can facilitate the effective integration of e-scooters into urban transport systems. This integration is expected to deliver meaningful societal benefits, including reduced environmental impact, better mobility options,

and enhanced economic sustainability [4]. The growing demand for both passenger and freight transport, driven by rapid urbanization—especially within the European Union—has made electric scooters an increasingly relevant component of shared mobility services since their emergence in 2017. One study examined an optimization challenge related to the nightly collection of e-scooters from Vienna's streets. A key issue for rental operators is the unpredictability of service times, specifically the time required to locate and load scooters onto collection vehicles. The study aimed to minimize the number of vans used, the total distance traveled, and penalties for late retrievals. The problem was formulated as an extension of the vehicle routing problem, with real-world data used to create practical test cases. A solution approach based on a large neighborhood search algorithm was developed, and scenario analyses were conducted to evaluate how service time variability influenced system costs. Additionally, a dynamic re-optimization strategy that incorporated real-time service time data was proposed. Results demonstrated that, depending on the standard deviation, the dynamic method reduced delays by 49–54% and achieved 4–17% better performance than the static approach [3]. Another study explored the dynamic behavior and energy consumption of an electric scooter by manipulating key input variables such as rider mass, scooter mass, wind speed, wheel radius, and slope gradient. A simulation model was developed in MATLAB-Simulink to estimate performance parameters including scooter velocity, required power, battery voltage, and propulsion torque. The results showed that reducing scooter weight from 26 to 10 kg increased velocity by 3.9% and energy consumption by 0.08%. Similarly, lowering the slope gradient from 1.15% to 0% led to decreases of 8.56% in required power, 0.55% in energy use, and 23.2% in velocity. When wind speed dropped from 4 to 0 m/s, energy consumption and required power improved by 0.2% and 5.5%, respectively. Conversely, increasing the wheel radius from 0.105 m to 0.185 m caused a 36.5% rise in velocity, a 34.3% increase in required power, and a slight 0.2% rise in energy consumption. The findings suggest that optimal performance can be achieved with a 10 kg scooter, a 0.185 m wheel radius, no wind, a level slope, and a light rider. The simulation results were validated through a parallel experiment, and both sets of findings were in close agreement [5]

3. Methodology

The electric scooter was developed through a systematic engineering and design process aimed at creating an efficient, sustainable, and user-friendly vehicle for short-distance urban travel. The development approach comprised several key stages, including concept formulation, component selection, system integration, fabrication, and performance evaluation. Initially, a conceptual framework was established to minimize environmental impact and reduce dependence on fossil fuels. A battery-powered DC motor was selected as the propulsion system due to its simplicity, reliability, and high efficiency. To enhance energy utilization, an innovative gearbox and clutch mechanism uncommon in conventional electric scooters was incorporated, allowing improved torque control and mechanical power transmission. Lightweight materials, particularly aluminum and composite elements, were used for the frame construction to decrease overall mass, thereby improving acceleration and energy efficiency. Aerodynamic features were integrated into the body design to reduce air resistance while enhancing visual appeal. The electrical subsystem was designed to ensure optimal battery management and precise motor control, whereas a mechanical powertrain system replaced traditional electronic speed controllers to minimize the risk of

electronic failure and simplify fault diagnosis. Finally, the assembled prototype underwent real-world performance testing under diverse operating conditions. Key parameters, including speed, torque, battery life, and braking performance, were measured and compared with theoretical predictions. This experimental evaluation validated the design choices and identified further opportunities for optimization in future iterations.

4. Designing & Fabrication of Electric Scooter

4.1 Designing of Electric Scooter

Designed for urban mobility purposes, the electric scooter design prioritizes usability, efficiency, and practicality. To guarantee structural stability and transportation, a sturdy yet lightweight aluminium frame was used. The scooter's foldable mechanism makes it easy to store and move around in small areas. To ensure sufficient range and speed for short-distance commuting, a balanced electric motor and battery system combination was used. The design incorporates a reliable braking mechanism, an easy-to-use handlebar interface for real-time monitoring, and pneumatic tires for increased ride comfort in order to improve user experience and operational safety. A kickstand, water-resistant shell, and integrated LED lighting are among further features that increase the scooter's adaptability and usefulness in a variety of urban settings

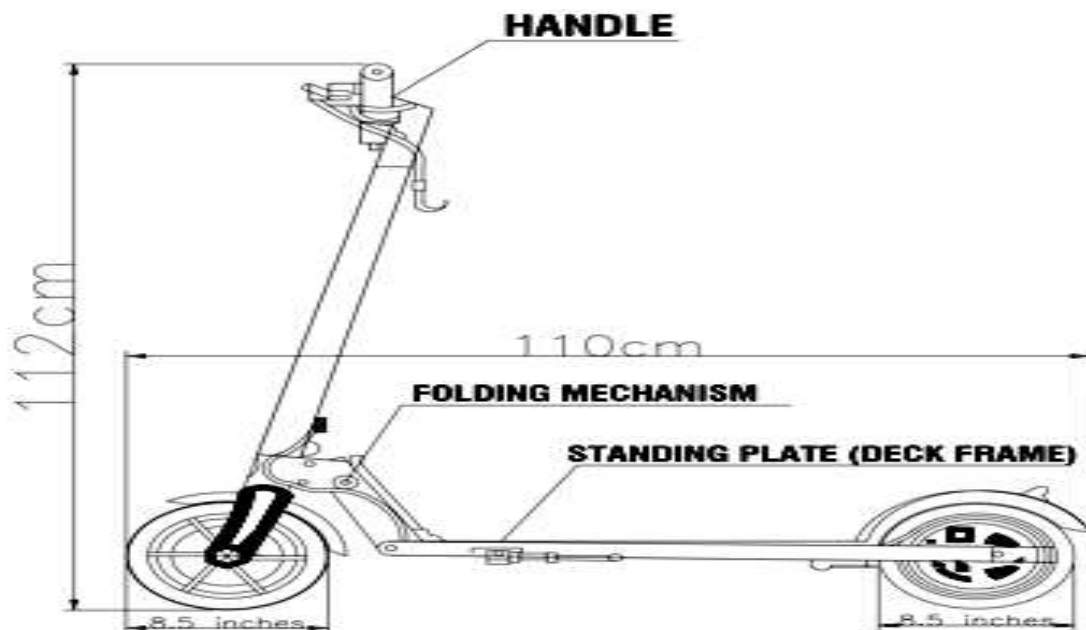

Figure 1 AutoCAD Model of Electric Scooter

4.2 Selection of Material for Fabrication of Electric Scooter

The choice of materials is crucial in automotive engineering since it affects the vehicle's overall sustainability, safety, and performance. Key factors such as low weight, mechanical strength, cost-effectiveness, recyclability, and lifetime durability were taken into consideration when choosing the materials for the electric scooter's body and chassis. A cost-

per-property study was used, with the strength-to-weight ratio as the main criterion, in order to provide an objective comparison. By choosing candidates that had the best performance at the lowest cost, this strategy made it possible to efficiently filter down the material possibilities. Table No. 01 lists the materials chosen for this study together with their corresponding mechanical characteristics.

Table 1 Material Specification

Material	Tensile strength (MPa)	Yield strength (MPa)	Young's modulus (GPa)	Toughness MN m-3/2	Density (Mg/m3)
Steel (1020)	380	200	210	140	7.8
Titanium Alloy (Ti-alloy)	950	910	100	85	4.5
Carbon Fiber Reinforced Polymer (CFRP)	550	200	56	38	1.5
Kenaf Fiber Reinforced Polymer (KFRP)	1380	621	76	39	1.4
Glass Fiber Reinforced Polymer (GFRP)	530	125	26	40	1.8

Because of its exceptional durability and strength-to-weight ratio, aluminum alloy A6061 is frequently used in the production of electric scooter. Because of its exceptional corrosion resistance, this alloy is crucial for preserving the scooter functionality and lifetime under a variety of environmental circumstances. Its structural integrity guarantees a sturdy and dependable frame, while its lightweight design adds to the scooter overall effectiveness and agility. Furthermore, Aluminum Alloy A6061 is renowned for its excellent machinability and workability, which makes it the perfect material for creating durable, high-quality electric scooter.

Property	Value	Units
Yield Strength	240 - 270	MPa
Tensile Strength	310 - 350	MPa
Elongation at Break	10 - 12	%
Elasticity	68.9	GPa
Toughness	~30	J/cm ³
Density	2.70	g/cm ³
Hardness	95 - 105 (Brinell)	HB
Thermal Conductivity	167	W/m·K
Melting Point	582 - 652	°C
Corrosion Resistance	Good	–
Fatigue Strength	96	MPa

Table 2 Material Specification

During the fabrication of the electric scooter, the primary objective of this paper is to utilize lightweight materials that enhance speed and optimize battery performance. The weight and dimensions of the fabricated electric scooter are provided below.

S. No	Components	Value
01	Frame	5-5.5 kg
02	Battery	1.6-1.8 kg
03	Motor	1.4-1.8 kg
04	Wheels	0.9-1.4 kg
05	Handlebars & Controls	0.9-1.4 kg
06	Rider	80-85 kg

Table 3 Weight of Components

S. No	Fabricated Electric Scooter Specification	Units
01	Length	43.3 inches (110 cm)
02	Width	17.5 inches (44.5 cm) [measured at handlebars]
03	Height	44.1 inches (112 cm)
04	Wheelbase	35 inches (89 cm) [between front and rear wheel axles]
05	Ground Clearance	4.3 inches (11 cm)
06	Tire Size	8.5 inches (21.6 cm)

Table 4 Specification of Fabricated Electric Scooter

S. No	Battery	Units
01	Battery Capacity	36V, 5.2Ah
02	Battery Weight	3.5-4 lbs (1.6-1.8 kg)
03	Battery Dimensions	29 cm × 3.8 cm × 7.4 cm
04	Range per Charge	Up to 12 miles (19 km)

Table 5 Specifications of Battery

S. No	Hub motor (Brushless Direct Current)	Units
01	Motor Power	250W
02	Motor Weight	3-4 lbs (1.4-1.8 kg)
03	Motor Dimensions	4.3 inches (11 cm)

Table 6 Specifications of Hub Motor

4.3 Manufacturing Process

The manufacture of the electric scooter follows an organized multi-stage process, beginning with conceptual design and finishing in final assembly and testing. The design and prototyping phase focuses on aesthetics, ergonomics, and functional performance, confirmed by iterative testing. Lightweight materials, mostly aluminum alloys, are precisely cut, welded, and surface treated during the frame-making process to guarantee longevity and resistance to corrosion. Important parts including the controller, battery, motor, and electronic systems are either produced internally or purchased from approved vendors. Wiring, electronics, driving systems, and structural components are all integrated throughout the assembly process. To guarantee effective power delivery, the motor and battery systems are firmly installed and connected. Wheels, brakes, and auxiliary parts like lighting and displays are installed during final assembly. During the procedure, thorough quality checks

4.4 POST ASSEMBLY

Following assembly, each electric scooter undergoes comprehensive post-assembly evaluation to ensure safety, functionality, and compliance with design specifications.

4.4.1 Performance and Safety Testing

To assess speed, acceleration, braking effectiveness, and range, the scooter is put through performance tests in a variety of loads, environments, and terrains. In order to ensure user safety in a variety of working settings, extensive safety testing is carried out to confirm electrical insulation, brake reliability, structural integrity, and water resistance.

4.4.2 Quality Control

A final quality inspection is performed to identify cosmetic defects, misalignments, or assembly inconsistencies. Functional checks validate key features such as lighting systems, display units, and folding mechanisms. Units failing inspection are reworked or rejected, ensuring only fully compliant scooters proceed to market.



Figure 2 Fabricated Electric Scoote

Results and Discussion

5.1 Vehicle Testing

After fabrication of the model the physical testing is as follows. The results obtained after testing are almost near to the design calculations.

S. No	Name	Value	Unit
01	Maximum Distance covered in one charge	19	Km
02	Battery	36V 5.2Ah Lithium-ion	Ampere hour
03	Charging Time Required	4-5	Hours
04	Maximum Speed	25	Km/h

Table 7 Vehicle Testing

5.1.1 Comparison of speed and battery consumption

With its 36V 5.2Ah Lithium-ion battery, the electric scooter can travel up to 12 miles (19 km) on average between charges. Environmental circumstances, topography, rider weight, and speed all affect how well the battery performs. Notably, the scooter total range is reduced when riding at its top speed of 15.5 mph (25 km/h), which results in increased power consumption. On the other hand, keeping a reasonable speed, such as 10 mph (16 km/h), enables longer travel lengths and prolongs battery life. Speed and battery efficiency must be balanced for best use, particularly when maximizing range or reducing recharge frequency are the objectives.



Figure 3 Comparisons of Maximum Speed and Average Speed

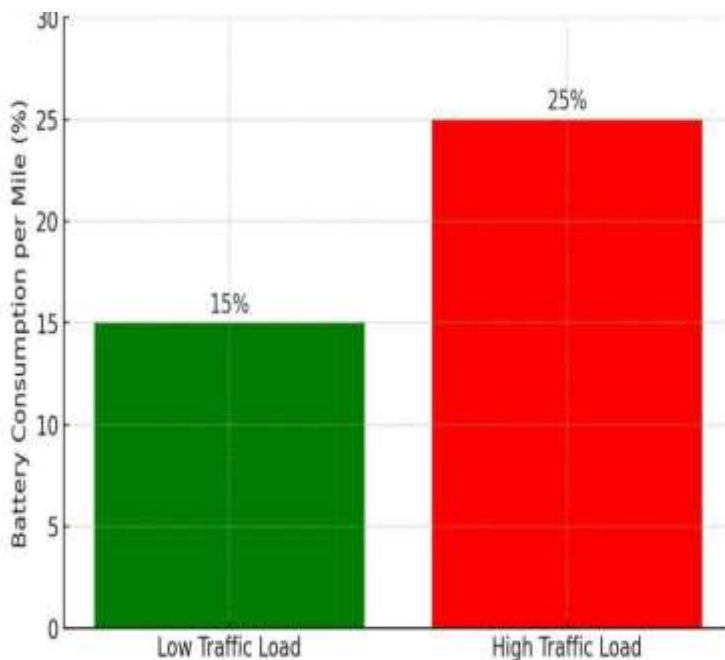

Figure 4 Comparison of Battery Capacity

6. Conclusion

This electric scooter provides a well-rounded blend of affordability, functionality, and convenience, making it a notable choice in the budget-friendly segment. Key highlights include:

- **Performance:** Featuring a 250W motor, it offers adequate power for daily commutes and moderate hills. Its speed and range are suitable for shorter to mid-range trips.

- **Design and Build:** The scooter boasts a compact, foldable design for easy portability and storage. While the build is durable, it may not match the sturdiness of more premium options.
- **Battery Life:** The scooter's battery delivers a reasonable range on a single charge, though actual performance may vary based on factors like traffic and terrain.
- **Comfort and Safety:** It comes with front and rear brakes for safety, though the ride may be less smooth on uneven surfaces due to its basic suspension system

7. Acknowledgment: The authors are grateful to Isra University Hyderabad, Sindh, Pakistan, for providing necessary help and facility to conduct this work.

8. Conflicts of Interest: The authors declare no conflicts of interest.

9. References

- D. Meister et al., "Localization and path following for an autonomous e-scooter," arXiv, May 2025.
- M. Z. Erel et al., "Solar energy-powered wireless charging system for three-wheeled e-scooter applications," *Renewable Energy*, p. 122933, 2025
- Sustainable electric micromobility through integrated power electronic systems and control strategies," *Energies*, vol. 18, no. 8, 2025
- Y. Ding et al., "Data-driven energy consumption modelling for electric micromobility using an open dataset," arXiv, Mar. 2024.
- S. Li et al., "Wireless capacitive power transfer: fundamentals and applications," *IEEE Access*, vol. 10, 2024.
- Title Unknown†, "Comparative assessment of a novel 8/18 multi-teeth with conventional 8/10 in-wheel SRM for an E-Scooter," *Arch. Mach. Des.*, 2024
- R. Strässer et al., "Collision avoidance safety filter for an autonomous E-Scooter using ultrasonic sensors," arXiv, Mar. 2024
- D. Chen et al., "Performance evaluation of real-time object detection for electric scooters," arXiv, May 2024
- K. Li et al., "Implementation of intelligent electric vehicle energy-efficiency control based on structure sharing," in *The Intelligent Environment Friendly Vehicle*, Springer, Jul. 2023
- A. Li et al., "Comparison of e-scooter sharing mobility: Evidence from 30 European cities," *Transp. Res. Part D: Transp. Environ.*, vol. 105, 2022
- K. Wang et al., "What travel modes do shared e-scooters displace? A review," *Transport Reviews*, 2022
- M.-D. Lin et al., "Stochastic location-allocation model for scooter battery swapping stations," *Sustainable Energy Technol. Assess.*, vol. 52, 2022
- E. Ayyildiz, "Pythagorean fuzzy multi-criteria for e-scooter charging station site selection," *Transp. Res. Part D*, vol. 111, 2022
- B. L. Grazian et al., "Voltage/current doubler converter for wireless charging of EVs," *IEEE Trans. Ind. Electron.*, vol. 70, 2022
- J. G. Schmidt et al., "Forecasts and impact on grid with expansion of EVs," in *IEEE/PES T&D*, 2022
- . H. Kwan et al., "A 110 W e-scooter wireless charger operating at 6.78 MHz," in *IEEE WPTC / WoW WPW*, San Diego, 2021

- V. Y. Kindl et al., "Inductive coupling system for electric scooter wireless charging," *Electr. Eng.*, vol. 102, 2020
- B. R. Lin, "Frequency control DC-DC converter for light electric vehicle applications," *Electronics*, vol. 10, 2021
- V. Kindl et al., "600 W 6.78 MHz wireless charger for an electric scooter," in *IEEE Wireless Power Week*, Seoul, 2020
- V. Shevchenko et al., "Losses model of the WPT system with single-phase T-Type inverter," in *IEEE IEPS*, Istanbul, 2020
- C. H. Kwan et al., "Design of a 100 W wireless charger for an E-Scooter at 6.78 MHz," in *IEEE WPTC / WoW*, London, 2019
- Hybrid energy storage system of an electric scooter based on wireless power transfer," *IEEE Trans. Ind. Inf.*, vol. 14, no. 9, 2018
- Y.-W. Chen et al., "Location optimization for multiple types of charging stations for e-scooters," *Appl. Soft Comput.*, vol. 67, 2018.
- J. Lu et al., "Wireless charger networking for mobile devices," *IEEE Wireless Commun.*, vol. 22, 2015
- S. Li and C. C. Mi, "Wireless power transfer for electric vehicle applications," *IEEE J. Emerg. Sel. Top. Power Electron.*, 2015